

SVA035-A



Features

- 1/3" WDR Sony CMOS Sensor
- AHD (720p) Resolution
- Extra Wide Viewing Angle 145° (2.5mm lens)
- 12pcs Infrared LEDs
- IP69K Weatherproof Certified
- Rugged Aluminum Housing
- 12 Infrared LEDs for Night-time Recording
- Simple and Secure Angle Control (360° Rotation)
- Flush Mount Option Hides Cables from Exposure
- Secure Aviator Cable Connector
- 5, 10, 15, or 20m Extension Cable Length Available



1/3 WDR
CMOS SENSOR



DAY & NIGHT



WDR
WIDE
DYNAMIC RANGE



DNR
DIGITAL NOISE
REDUCTION



DPC
DEAD PIXEL
COMPENSATION



LSC
LENS SHADING
COMPENSATION



2.5mm
BOARD LENS



DC 12V



IP69K

Dimensions

unit: mm

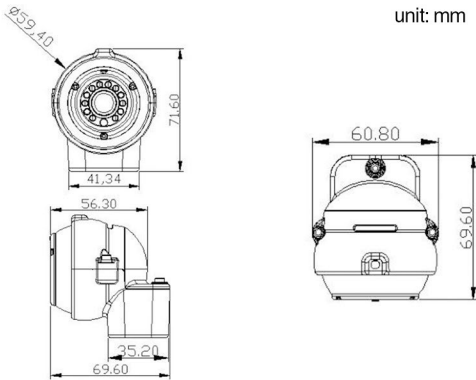

Cable



Extension Cable available in 5m, 10m, 15m, 20m

Alternative Views



Specifications

SVA035-A	
Image Device	1.3 Mega-Pixel Sony CMOS Sensor
Image Processor	NVP 2431
Effective Pixels	1305(H) x 1049(V) = 1.37M
TV Mode	NTSC / PAL
Video Output	AHD : 1.0 (720P) / CVBS : 1Vp-p ±10%, 75Ω
Scanning Mode	Progressive
Synchronization	Internal
Sensitivity	0.1Lux (F1.2, @50IRE)
S/N Ratio	More than 50dB AGC OFF
White Balance	2000 ~ 8000K Automatic tracking
BLC	Off / Low / Middle / High
D-WDR	Off / Low / Middle / High
AGC	Off / Low / Middle / High
Mirror	ON/OFF (Option)
IR LED	12 IR LEDs
DAY&NIGHT	True Day / Night
Night View Distance	8m
Lens	2.5mm lens(145°) [3 MEGA LENS]
Power Supply	DC12V: 150mA (LED ON) / 80mA (LED OFF) [DC 7V ~ DC 43V]
Storage Temperature	-30°C ~ +80°C
Operating Temperature	-20°C ~ +60°C (Humidity : 10%~85% RH)
Dimensions	60.8mm(W) x 69.6mm(D) x 71.6mm(H)
Housing Color	Black